

DENON

DOUBLE CD PLAYER

DN-2700F

OPERATING INSTRUCTIONS

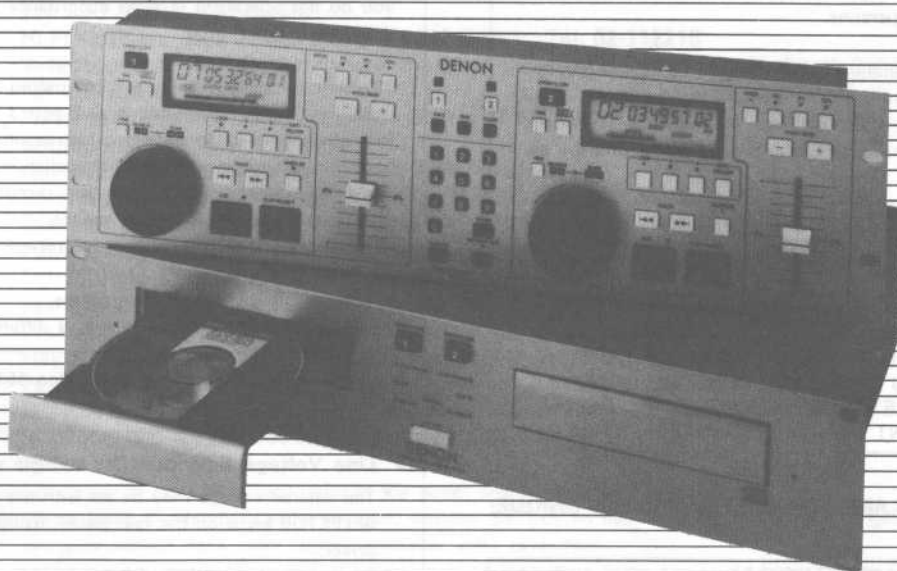

IMPORTANT TO SAFETY

WARNING:

TO PREVENT FIRE OR SHOCK HAZARD, DO NOT EXPOSE THIS APPLIANCE TO RAIN OR MOISTURE.

CAUTION:

1. Handle the power supply cord carefully

Do not damage or deform the power supply cord. If it is damaged or deformed, it may cause electric shock or malfunction when used. When removing from wall outlet, be sure to remove by holding the plug attachment and not by pulling the cord.

2. Do not open the top cover

In order to prevent electric shock, do not open the top cover. If problems occur, contact your DENON dealer.

3. Do not place anything inside

Do not place metal objects or spill liquid inside the CD player. Electric shock or malfunction may result.

Please, record and retain the Model name and serial number of your set shown on the rating label.

Model No. DN-2700F

Serial No. _____



CAUTION
RISK OF ELECTRIC SHOCK
DO NOT OPEN



CAUTION: TO REDUCE THE RISK OF ELECTRIC SHOCK, DO NOT REMOVE COVER (OR BACK). NO USER-SERVICEABLE PARTS INSIDE. REFER SERVICING TO QUALIFIED SERVICE PERSONNEL.



The lightning flash with arrowhead symbol, within an equilateral triangle, is intended to alert the user to the presence of uninsulated "dangerous voltage" within the product's enclosure that may be of sufficient magnitude to constitute a risk of electric shock to persons.



The exclamation point within an equilateral triangle is intended to alert the user to the presence of important operating and maintenance (servicing) instructions in the literature accompanying the appliance.

NOTE:

This CD player uses the semiconductor laser. To allow you to enjoy music at a stable operation, it is recommended to use this in a room of 5 °C (41 °F) –35 °C (95 °F).

• FOR U.S.A. & CANADA MODEL ONLY

CAUTION

TO PREVENT ELECTRIC SHOCK DO NOT USE THIS (POLARIZED) PLUG WITH AN EXTENSION CORD, RECEPTACLE OR OTHER OUTLET UNLESS THE BLADES CAN BE FULLY INSERTED TO PREVENT BLADE EXPOSURE.

LABELS (for U.S.A. model only)

CERTIFICATION

THIS PRODUCT COMPLIES WITH DHHS RULES 21 CFR SUBCHAPTER J APPLICABLE AT DATE OF MANUFACTURE.

CAUTION:

USE OF CONTROLS OR ADJUSTMENTS OR PERFORMANCE OF PROCEDURES OTHER THAN THOSE SPECIFIED HEREIN MAY RESULT IN HAZARDOUS RADIATION EXPOSURE.

THE COMPACT DISC PLAYER SHOULD NOT BE ADJUSTED OR REPAIRED BY ANYONE EXCEPT PROPERLY QUALIFIED SERVICE PERSONNEL.

This device complies with Part 15 of the FCC Rules. Operation is subject to the following two conditions : (1) This device may not cause harmful interference, and (2) this device must accept any interference received, including interference that may cause undesired operation.

This Class B digital apparatus meets all requirements of the Canadian Interference-Causing Equipment Regulations.

Cet appareil numérique de la classe B respecte toutes les exigences du Règlement sur le matériel brouilleur du Canada.

CLASS 1 LASER PRODUCT
LUOKAN 1 LASERLAITE
KLASS 1 LASERAPPARAT

"CLASS 1
LASER PRODUCT"

ADVARSEL: USYNLIG LASERSTRÅLING VED ÅBNING, NÅR SIKKERHEDSAFBRYDERE ER UDE AF FUNKTION. UNDGÅ UDSÆTTELSE FOR STRÅLING.

VAROITUS! LAITTEEN KÄYTTÄMINEN MUULLA KUIN TÄSSÄ KÄYTTÖOHJEESSA MAINITULLA TAVALLA SAATTAA ALTISTAA KÄYTTÄJÄN TURVALLISUUSLUOKAN 1 YLITTÄVÄLLE NÄKYMÄMTTÖMÄLLE LASERSÄTEILYLLE.

VARNING- OM APPARATEN ANVÄNDS PÅ ANNAT SÄTT ÄN I DENNA BRUKSANVISNING SPECIFICERATS, KAN ANVÄNDAREN UTSÄTTAS FÖR OSYNLIG LASERSTRÅLNING SOM ÖVERSKRIDER GRÄNSEN FÖR LASERKLASS 1.



• POUR LES MODELES AMERICAINS ET CANADIENS UNIQUEMENT

ATTENTION

POUR PREVENIR LES CHOCS ELECTRIQUES NE PAS UTILISER CETTE FICHE POLARISEE AVEC UN PROLONGATEUR UNE PRISE DE COURANT OU UNE AUTRE SORTIE DE COURANT, SAUF SI LES LAMES PEUVENT ETRE INSEREES A FOND SANS EN LAISSER AUCUNE PARTIE A DECOUVERT.

SAFETY INSTRUCTIONS

1. Read Instructions – All the safety and operating instructions should be read before the appliance is operated.
2. Retain Instructions – The safety and operating instructions should be retained for future reference.
3. Heed Warning – All warnings on the appliance and in the operating instructions should be adhered to.
4. Following Instructions – All operating and use instructions should be followed.
5. Water and Moisture – The appliance should not be used near water – for example, near a bathtub, washbowl, kitchen sink, laundry tub, in a wet basement, or near a swimming pool, and the like.
6. Carts and Stands – The appliance should be used only with a cart or stand that is recommended by the manufacturer.
- 6A. An appliance and cart combination should be moved with care. Quick stops, excessive force, and uneven surfaces may cause the appliance and cart combination to overturn.
7. Wall or Ceiling Mounting – The appliance should be mounted to a wall or ceiling only as recommended by the manufacturer.
8. Ventilation – The appliance should be situated so that its location or position does not interfere with its proper ventilation. For example, the appliance should not be situated on a bed, sofa, rug, or similar surface that may block the ventilation openings; or, placed in a built-in installation, such as a bookcase or cabinet that may impede the flow of air through the ventilation openings.
9. Heat – The appliance should be situated away from heat sources such as radiators, heat registers, stoves, or other appliances (including amplifiers) that produce heat.
10. Power Sources – The appliance should be connected to a power supply only of the type described in the operating instructions or as marked on the appliance.
11. Grounding or Polarization – Precautions should be taken so that the grounding or polarization means of an appliance is not defeated.



12. Power-Cord Protection – Power-supply cords should be routed so that they are not likely to be walked on or pinched by items placed upon or against them, paying particular attention to cords at plugs, convenience receptacles, and the point where they exit from the appliance.
14. Cleaning – The appliance should be cleaned only as recommended by the manufacturer.
15. Power Lines – An outdoor antenna should be located away from power lines.
16. Outdoor Antenna Grounding – If an outside antenna is connected to the receiver, be sure the antenna system is grounded so as to provide some protection against voltage surges and built-up static charges. Article 810 of the National Electrical Code, ANSI/NFPA 70, provides information with regard to proper grounding of the mast and supporting structure, grounding of the lead-in wire to an antenna-discharge unit, size of grounding conductors, location of antenna-discharge unit, connection to grounding electrodes, and requirements for the grounding electrode. See Figure A.
17. Nonuse Periods – The power cord of the appliance should be unplugged from the outlet when left unused for a long period of time.
18. Object and Liquid Entry – Care should be taken so that objects do not fall and liquids are not spilled into the enclosure through openings.
19. Damage Requiring Service – The appliance should be serviced by qualified service personnel when:
 - A. The power-supply cord or the plug has been damaged; or
 - B. Objects have fallen, or liquid has been spilled into the appliance; or
 - C. The appliance has been exposed to rain; or
 - D. The appliance does not appear to operate normally or exhibits a marked change in performance; or
 - E. The appliance has been dropped, or the enclosure damaged.
20. Servicing – The user should not attempt to service the appliance beyond that described in the operating instructions. All other servicing should be referred to qualified service personnel.

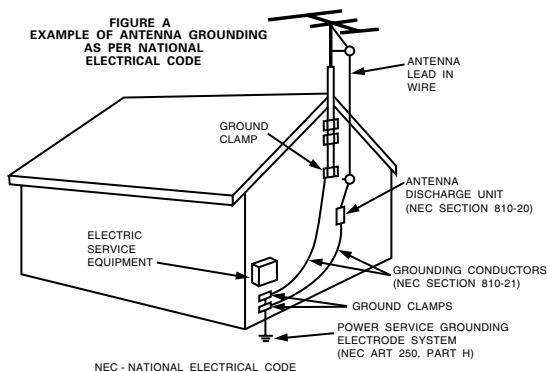

**NOTE ON USE / HINWEISE ZUM GEBRAUCH / OBSERVATIONS RELATIVES A L'UTILISATION
NOTAS SOBRE EL USO / ALVORENS TE GEBRUIKEN / OBSERVERA**

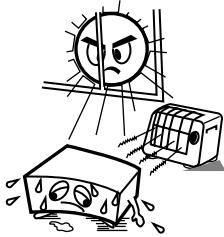

- Avoid high temperatures. Allow for sufficient heat dispersion when installed on a rack.
- Vermeiden Sie hohe Temperaturen. Beachten Sie, daß eine ausreichend Luftzirkulation gewährleistet wird, wenn das Gerät auf ein Regal gestellt wird.
- Eviter des températures élevées. Tenir compte d'une dispersion de chaleur suffisante lors de l'installation sur une étagère.
- Evite altas temperaturas. Permite la suficiente dispersión del calor cuando está instalado en la consola.
- Vermijd hoge temperaturen. Zorg voor een degelijk hitteafvoer indien het apparaat op een rek wordt geplaatst.
- Undvik höga temperaturer. Se till att det finns möjlighet till god värmeavledning vid monteringen i ett rack.

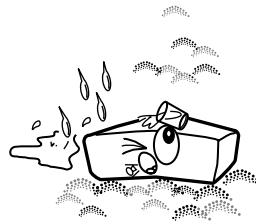

- Keep the set free from moisture, water, and dust.
- Halten Sie das Gerät von Feuchtigkeit, Wasser und Staub fern.
- Protéger l'appareil contre l'humidité, l'eau et la poussière.
- Mantenga el equipo libre de humedad, agua y polvo.
- Laat geen vochtigheid, water of stof in het apparaat binnendringen.
- Utsätt inte apparaten för fukt, vatten och damm.

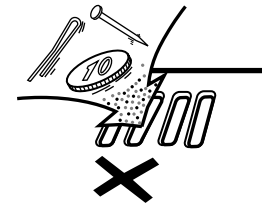

- Do not let foreign objects in the set.
- Keine fremden Gegenstände in das Gerät kommen lassen.
- Ne pas laisser des objets étrangers dans l'appareil.
- No deje objetos extraños dentro del equipo.
- Laat geen vreemde voorwerpen in dit apparaat vallen.
- Se till att främmande föremål inte tränger in i apparaten.

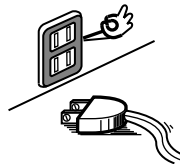

- Unplug the power cord when not using the set for long periods of time.
- Wenn das Gerät eine längere Zeit nicht verwendet werden soll, trennen Sie das Netzkabel vom Netzstecker.
- Débrancher le cordon d'alimentation lorsque l'appareil n'est pas utilisé pendant de longues périodes.
- Desconecte el cordón de energía cuando no utilice el equipo por mucho tiempo.
- Neem altijd het netsnoer uit het stopcontact wanneer het apparaat gedurende een lange periode niet wordt gebruikt.
- Koppla ur nätkabeln om apparaten inte kommer att användas i lång tid.



- Do not let insecticides, benzene, and thinner come in contact with the set.
- Lassen Sie das Gerät nicht mit Insektiziden, Benzin oder Verdünnungsmitteln in Berührung kommen.
- Ne pas mettre en contact des insecticides, du benzène et un diluant avec l'appareil.
- No permita el contacto de insecticidas, gasolina y diluyentes con el equipo.
- Laat geen insektenverdelgende middelen, benzine of verfverdunder met dit apparaat in contact komen.
- Se till att inte insektsmedel på spraybruk, bensen och thinner kommer i kontakt med apparatens hölje.

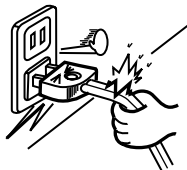

- Handle the power cord carefully. Hold the plug when unplugging the cord.
- Gehen Sie vorsichtig mit dem Netzkabel um. Halten Sie das Kabel am Stecker, wenn Sie den Stecker herausziehen.
- Manipuler le cordon d'alimentation avec précaution. Tenir la prise lors du débranchement du cordon.
- Maneje el cordón de energía con cuidado. Sostenga el enchufe cuando desconecte el cordón de energía.
- Hanteer het netsnoer voorzichtig. Houd het snoer bij de stekker vast wanneer deze moet worden aan- of losgekoppeld.
- Hantera nätkabeln varsamt. Håll i kabeln när den kopplas från el-uttaget.

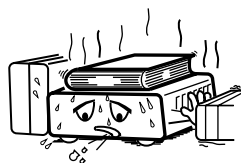

* (For sets with ventilation holes)

- Do not obstruct the ventilation holes.
- Die Belüftungsöffnungen dürfen nicht verdeckt werden.
- Ne pas obstruer les trous d'aération.
- No obstruya los orificios de ventilación.
- De ventilatieopeningen mogen niet worden geblokkeerd.
- Täpp inte till ventilationsöppningarna.

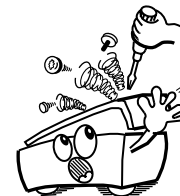

- Never disassemble or modify the set in any way.
- Versuchen Sie niemals das Gerät auseinander zu nehmen oder auf jegliche Art zu verändern.
- Ne jamais démonter ou modifier l'appareil d'une manière ou d'une autre.
- Nunca desarme o modifique el equipo de ninguna manera.
- Nooit dit apparaat demonteren of op andere wijze modifieren.
- Ta inte isär apparaten och försök inte bygga om den.

MAIN FEATURES

The DN-2700F is a double CD player which incorporates all of the popular functions from the DN-2000F and adds additional features for more advanced DJ mixing and remixing.

- (1) The DN-2700F can be easily mounted on a standard 19-inch rack.
- (2) The player unit and control unit are connected by a single cord, providing installation freedom.
- (3) Playback begins immediately when the PLAY button is pressed. (Instant Start)
- (4) Pitch is adjustable using a long-throw slider, providing an analog feel.
- (5) The pitch can be changed temporarily based on the already adjusted pitch. (Pitch Bend)
- (6) The point at which the sound actually starts is searched for automatically when a track is selected, eliminating troublesome searching operations. (Cue to Music)
- (7) Searching is possible in units of single frames (1/75 of a second), the minimum time unit on CDs, for maximum precision.

In addition to the above functions (all provided on the DN-2000F), the DN-2700F also includes the following functions:

- (8) The range of the pitch control slider is selectable between $\pm 4\%$, $\pm 8\%$ and $\pm 50\%$.
- (9) A Loop feature allows you to select arbitrary start and end points and continuously loop between them. No sampler is necessary. (Seamless Loop)
- (10) A Sampler function is included which provides nearly six seconds of CD quality stereo sampling per side. Sample playback is triggered from the PLAY/PAUSE button while in sample mode. (Sampler)
- (11) Familiar Jog/Shuttle dial controls allow fast and accurate searching of CD's.
- (12) The search precision of the jog wheel is selectable between ± 1 frame and ± 10 frames.
- (13) Memory playback (w/disc identification feature) provides storage of start and end points for automated play operation.
- (14) Random playback with two discs.
- (15) Direct access to any location on a CD using the number keys.

DN-2700F MAIN UNIT
FRONT PANEL

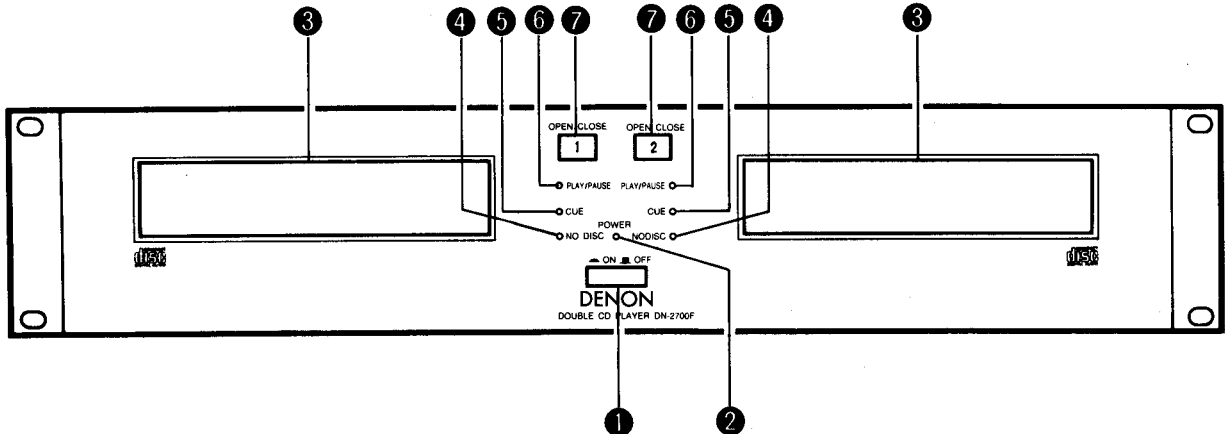

Figure 1

RC-37 CONTROL UNIT
FRONT PANEL

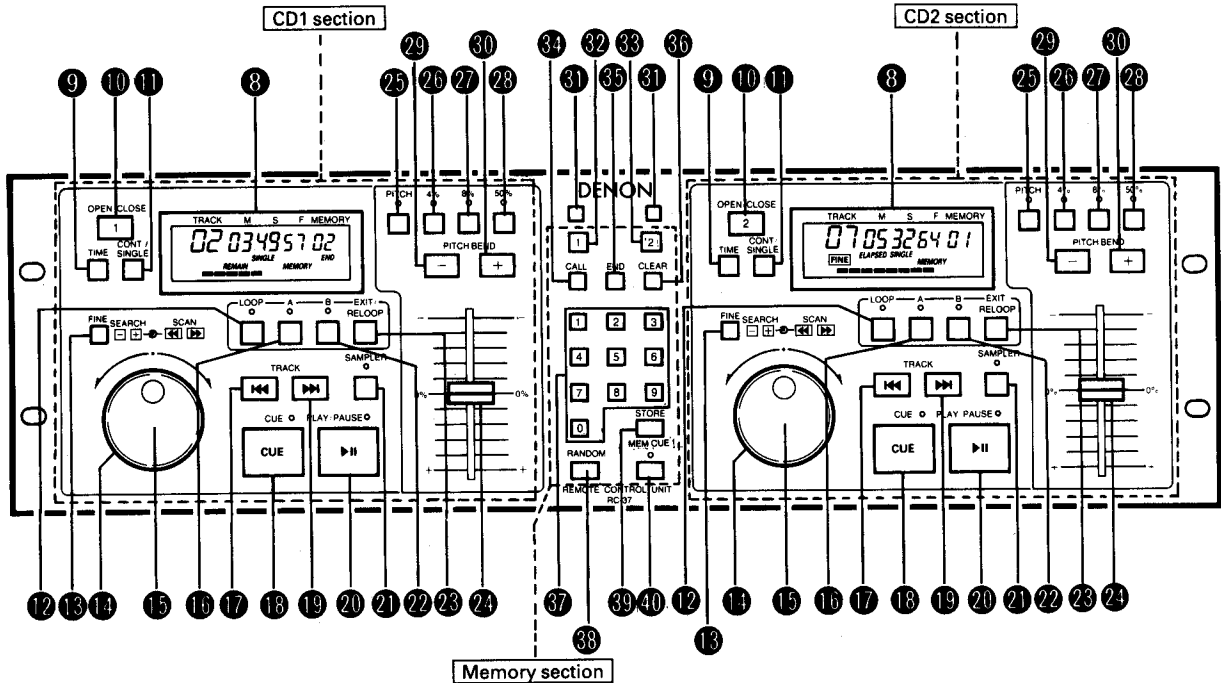

Figure 2

DN-2700F FRONT PANEL

- ① POWER (Power ON/OFF Switch)
- ② POWER (Power On Indicator)
- ③ Disc Holder
- ④ NO DISC (No Disc Indicator)
- ⑤ CUE (Cue Indicator)
- ⑥ PLAY/PAUSE (Play/Pause Indicator)
- ⑦ OPEN/CLOSE (Open/Close Button)

RC-37 FRONT PANEL

- ⑧ LCD (Liquid Crystal Display)
- ⑨ TIME (Time Button)
- ⑩ OPEN/CLOSE (Open/Close Button)
- ⑪ CONT./SINGLE (Continue/ Single Button)
- ⑫ LOOP (Loop Button)
- ⑬ FINE (Fine Search Button)
- ⑭ Shuttle Dial
- ⑮ Jog Dial

DIMENSIONS

DN-2700F

- 16 A (A Button)
- 17 TRACK IH (Track Down Button)
- 18 CUE (Cue Button)
- 19 TRACK NI (Track Up Button)
- 20 PLAY/PAUSE (Play/Pause Button)
- 21 SAMPLER (Sampler Button)
- 22 B (B Button)
- 23 EXIT/RELOOP (Exit/Reloop Button)
- 24 Pitch Slider
- 25 PITCH (Pitch Button)
- 26 4% (4% Button)
- 27 8% (8% Button)
- 28 50% (50% Button)
- 29 PITCH BEND- (Pitch Bend- Button)
- 30 PITCH BEND+ (Pitch Bend+ Button)
- 31 Beat Indicator
- 32 1 (CD1 Button)
- 33 2 (CD2 Button)
- 34 CALL (Call Button)
- 35 END (End Button)
- 36 CLEAR (Clear Button)
- 37 0 ~ 9 (Number Buttons)
- 38 RANDOM (Random Button)
- 39 STORE (Store Button)
- 40 MEM CUE (Memory Cue Button)
- 41 LINE OUT (Output Jack)
- 42 REMOTE (Control Connector)
- 43 Voltage Selector (Multi-voltage models only)
- 44 Control Connector

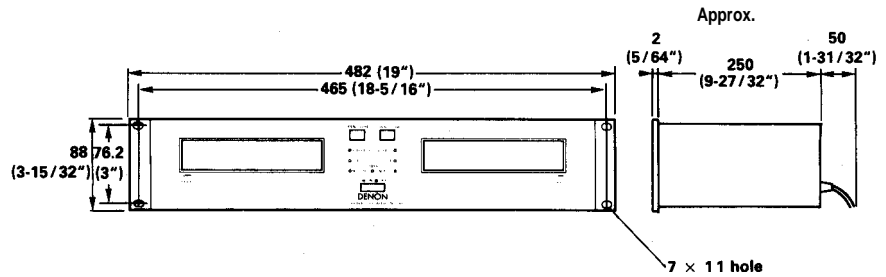

REAR PANEL

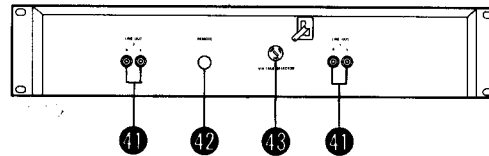
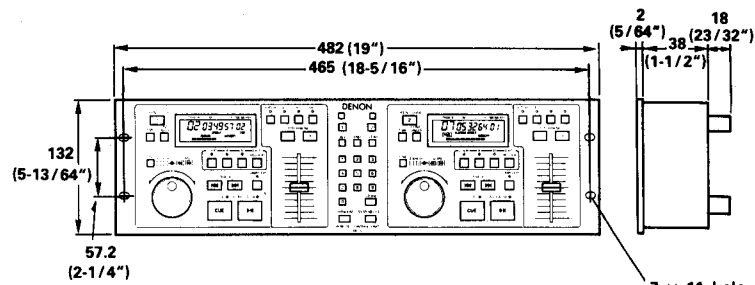

Figure 3

RC-37



REAR PANEL

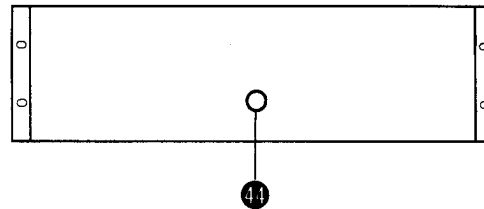

Figure 4

LCD

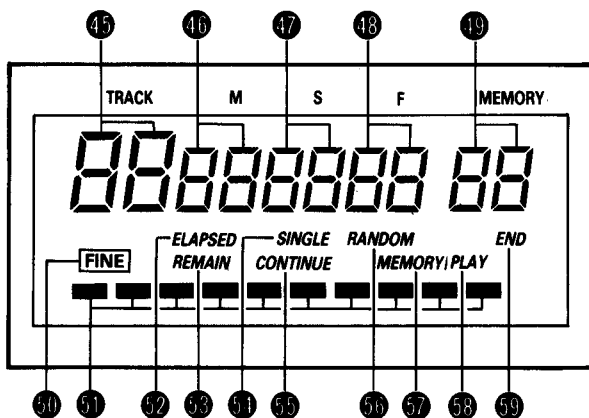

Figure 5

- 45 TRACK (Track Display)
- 46 MINUTE (Minute Display)
- 47 SECOND (Second Display)
- 48 FRAME (Frame Display)
- 49 MEMORY (Memory Number Display)
- 50 FINE (Fine Search Indicator)
- 51 Bar Indicator
- 52 ELAPSED (Elapsed Time Indicator)
- 53 REMAIN (Remaining Time Indicator)
- 54 SINGLE (Single Indicator)
- 55 CONTINUE (Continue Indicator)
- 56 RANDOM (Random Indicator)
- 57 MEMORY (Memory Indicator)
- 58 PLAY (Play Indicator)
- 59 END (End Indicator)

CONTENTS

1	PREPARATIONS	9	6	LOOP	17,18
	(1) Checking the Contents	9		(1) Basic Loop Operation	17
	(2) Installing the Units	9		(2) Starting Loop Playback From a Cue Point Before The Normal Start Point "A" ..	18
	(3) Connections	9		(3) Exit and Re-loop	18
2	NAMES AND FUNCTIONS	10,11	7	MEMORY	19 ~ 24
	(1) DN-2700F (Main Unit) Front Panel	10		(1) Types of Memory Playback Data	19
	(2) RC-37 (Control Unit) Front Panel	10		(2) Disc Identification	19
	(3) DN-2700F (Main Unit) Rear Panel	11		(3) Inputting the Memory Data	20-22
	(4) RC-37 (Control Unit) Rear Panel	11		(4) Executing Memory Playback	23
	(5) LCD	11		(5) Cue to Memory	24
3	BASIC OPERATIONS	12~ 15		(6) Memory Call	24
	(1) Opening and Closing the Disc Holder and Loading Discs	12		(7) Clearing all Memory Data	24
	(2) Selecting Tracks	12		(8) Advanced Memory Functions	24,25
	(3) Starting Playback	13	8	RANDOM PLAYBACK	25,26
	(4) Stopping Playback	13		(1) Preparing for Random Playback	25
	(5) Pausing	13		(2) Executing Random Playback.....	26
	(6) Cueing	14	9	DIRECT ACCESS	27
	(7) Searching	14	10	BEFORE SWITCHING OFF THE POWER	27
	(8) Scanning	15	11	COMPACT DISCS	27
4	MATCHING THE BEATS PER MINUTE (BPM)	15,16	12	SPECIFICATIONS	28
	(1) Pitch Slider	15			
	(2) Pitch Bending	16			
5	SAMPLER	16,17			
	(1) Recording the Sample	16			
	(2) Playing the Sample	17			
	(3) Cancelling the Sampler Mode	17			

1 PREPARATIONS

(1) Checking the Contents

Check that the carton contains the following items:

- ① DN-2700F (main unit)
- ② RC-37 (control unit)
- ③ Operating instructions (this booklet)
- ④ Pair of RCA pin cords
- ⑤ Control cord (5-meter, 15 feet)

(2) Installing the Units

Mount the units onto your console or rack with 19" EIA rack rails.

CAUTION:

- The DN-2700F will work normally when the main unit is mounted with the front panel within 20 degrees of the vertical plane. If the unit is tilted excessively, discs may not load or unload properly. (Figure 6)
- RC-37's LCDs are designed to be clearly visible within the angles shown in Figure 7. Mount the RC-37 so that the visual angle is within this range.

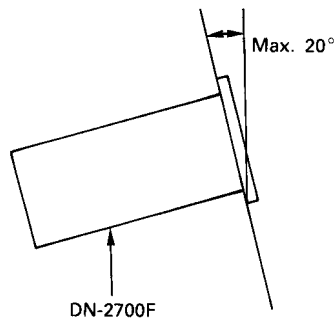

Figure 6

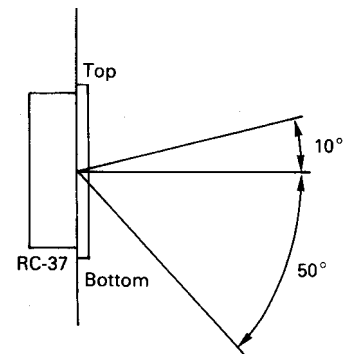

Figure 7

(3) Connections

- ① Turn off the POWER switch.
- ② Connect the RCA pin cords to the inputs on your mixer.
- ③ Connect the control cord to the REMOTE connector on the RC-37.

CAUTION:

- Be sure to use the supplied control cord. Using another type of cable may result in damage.
- Be sure the power is off when connecting the control cord. Otherwise the units may not work properly.

2 NAMES AND FUNCTIONS

Below is a description of the functions of the controls listed on Pages 6 and 7.

(1) DN-2700F (Main Unit) Front Panel

- 1 2 POWER (Power Switch and Indicator)
When the POWER switch is pressed, the power turns on and the POWER indicator lights.
- 3 Disc Holders
Place the discs in these holders. Press the OPEN/CLOSE buttons to open and close the disc holders.
- 4 NO DISC Indicators
These indicators light when the disc holders are open or when no discs are loaded.
- 5 CUE Indicators
These indicators flash during the cueing operation and light solid when the unit is cued.
- 6 PLAY/PAUSE Indicators
These indicators light during playback and flash when in the pause mode.
- 7 OPEN/CLOSE Buttons
Press these to open and close the disc holders. The control unit also includes OPEN/CLOSE buttons. The disc holders cannot be opened during playback, so playback must be stopped before pressing these buttons.

(2) RC-37 (Control Unit) Front Panel

- 8 LCD
These liquid crystal displays (LCDs) indicate the current track numbers, minutes, seconds, frames and memory location numbers.
- 9 TIME Buttons
These buttons switch the time display between elapsed time and remaining time. The selected mode is indicated by the ELAPSED and REMAIN indicators on the LCD.
- 10 OPEN/CLOSE Buttons
Press these to open and close the disc holders. The main unit also includes OPEN / CLOSE buttons. The disc holders cannot be opened during playback, so playback must be stopped before pressing these buttons.
- 11 CONT./SINGLE Buttons
Press these to switch between the single and continuous play modes. The selected mode is indicated by the SINGLE and CONTINUE indicators on the LCD.
- 12 LOOP Buttons
Press these buttons to start loop mode. The LOOP LED is lit solid during loop playback.

- 13 FINE Buttons
Use these buttons to select the resolution of the jog dial. When the fine mode is set the FINE indicator appears on the display, and the pickup moves one frame for each click of the jog dial. When the FINE indicator is off, the pickup moves 10 frames with each click.
- 14 Shuttle Dials
Use these dials to select the scanning direction and speed. The disc is scanned in the forward direction when the shuttle dial is turned clockwise from the neutral position, and in the reverse direction when the shuttle dial is turned counterclockwise. The scanning speed increases as the wheel is turned further.
- 15 Jog Dials
When these dials are turned during the search operation, the point at which the sound is being produced moves by a number of frames corresponding to the number of clicks (1 or 10 frames per click).
- 16 A Buttons
Use these buttons to set the starting point for loop playback. They can also be used as extra cue buttons when not in the loop mode.
- 17 19 TRACK ◀◀ and TRACK ▶▶ Buttons
Use these buttons to select the track to be played.
- 18 CUE Buttons
Press the CUE buttons during playback to return to the position at which playback started. The player is ready to play when the CUE LED stops flashing, remaining lit.
- 20 PLAY/PAUSE Buttons
Use these buttons to start playback. Press once to start playback, once again to set the pause mode, and once more to resume playback.
- 21 SAMPLER Buttons
Press these buttons to start recording the sample. Press the PLAY/PAUSE button after recording to set the sample play mode.
- 22 B Buttons
Use these buttons to set the end point for loop playback. They can also be used as extra cue buttons when not in the loop mode.
- 23 EXIT/RELOOP Button
Press these buttons during loop playback to stop loop playback and continue normal playback past the B point (exit), or to return to loop playback for a loop which was previously exited (reloop).

24 Pitch Sliders
Use these sliders to adjust the BPM. Slide up to decrease the BPM, down to increase the BPM.

25 PITCH Buttons
Use these buttons to enable or disable pitch adjustment using the pitch sliders. Pitch adjustment with the pitch slider is enabled when the PITCH LED is lit.

26 **27** **28** 4%, 8% and 50% Buttons
Use these buttons to select the range of pitch adjustment with the pitch sliders.

29 **30** PITCH BEND- and PITCH BEND+ Buttons
The pitch changes temporarily while these buttons are pressed. Release the buttons to return to the original BPM.

31 BEAT Indicators
These indicate the beat of the music currently playing.

32 **33** 1 and 2 Buttons
Use these buttons to select which player the number buttons will function for.

34 CALL Button
Press this button to display the contents of the memory steps in sequence.

35 END Button
Press this button during programming to enter the END point data for the current memory step. END point data may be entered using the number buttons or the Jog/Shuttle dials. When pressed, the END indicator on the LCD lights.

36 CLEAR Button
Press this button to clear the data which was input using the number buttons.

37 0 ~ 9 Buttons (Number Buttons)
Use these buttons to input track numbers and times (minutes and seconds).

38 RANDOM Button
Press this button to prepare the player for random playback.

39 STORE Button
Use this button to store previously entered START and/or END point data into memory.

40 MEMORY CUE Button
Use this button to cue each disc to its first memory step.

(3) DN-2700F (Main Unit) Rear Panel

41 LINE OUT 1 and 2
The audio signals from each player are output from these jacks.

42 REMOTE
Connect this connector to the RC-37 control unit using the included control cord.

43 Voltage Selector (multi-voltage model only)
On multi-voltage models, use this to select the power voltage. Always disconnect the power plug before changing the voltage.

(4) RC-37 (Control Unit) Rear Panel

44 Control Connector
Connect this connector to the REMOTE connector on the DN-2700F (main unit) using the included control cord.

(5) LCD

45 **46** **47** **48** TRACK, MINUTE, SECOND and FRAME Displays
Displays

These displays indicate information on the current position and time.

49 MEMORY Displays
These indicate the memory location number during programming or memory playback.

50 FINE Indicators
These indicate whether the jog dial resolution is at ± 1 frame (FINE) or ± 10 frames.

51 BAR Indicator
These ten indicators provide a visual display of the approximate position of the pickup within the current track.

52 ELAPSED Indicators
These indicate that the time shown on the display is the elapsed time.

53 REMAIN Indicators
These indicate that the time shown on the display is the remaining time.

54 SINGLE Indicators
When these indicators are lit, playback will stop at the end of the track.

55 CONTINUE Indicators
When these indicators are lit, playback will continue until the end of the disc.

56 RANDOM Indicators
These blink during preparation for random playback and are lit solid during random playback.

57 **58** MEMORY and PLAY Indicators
The MEMORY indicators light or blink when data has been stored in the memory. The PLAY indicators light during memory playback.

59 END Indicators
These indicators light during programming when the END button is pressed.

3 BASIC OPERATIONS

(1) Opening and Closing the Disc Holder and Loading Discs

① Opening and closing the disc holder

- This operation only works when the power is on.
- Press the OPEN/CLOSE button to open or close the disc holder. OPEN/CLOSE buttons are provided on both the main unit and control unit (RC-37).
- The disc holder cannot be opened during playback to prevent playback from being interrupted if the OPEN/CLOSE button is pressed accidentally. Stop playback, then press the OPEN/CLOSE button.

Loading discs

- Hold the disc by the edges and place it in the disc tray. Do not touch the signal surface (the glossy side).
- When using 12cm discs, place the disc in the outer tray guides (Figure 8), and when using 8cm discs, place them securely in the inner guides (Figure 9).

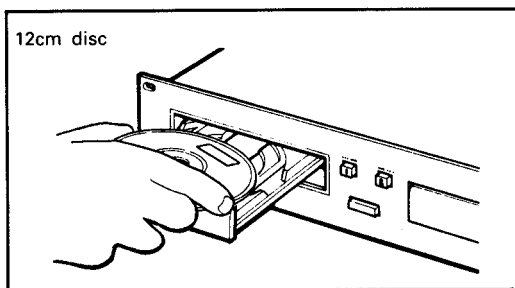

Figure 8

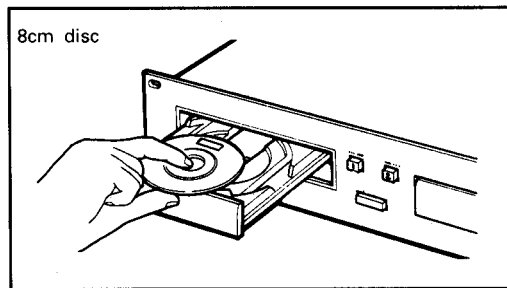

Figure 9

CAUTION:

- Do not place any foreign objects in the disc tray, and do not place more than one disc in the disc tray at a time. Doing so may result in malfunction.
- Do not push the disc tray in manually when the power is off, as this may result in malfunction and damage the player.

(2) Selecting Tracks

Press the TRACK buttons once to move to the next or preceding track.

Hold down the TRACK buttons to change tracks continuously at a higher speed.

When a new track is selected during playback, playback begins as soon as the search operation is completed.

Tracks can also be selected while the disc holder is open. The selected track is searched for when the disc holder is closed.

If the TRACK **▶▶** button is pressed while on the last track, the first track is selected. Likewise, if the TRACK **◀◀** button is pressed while on the first track, the last track is selected.

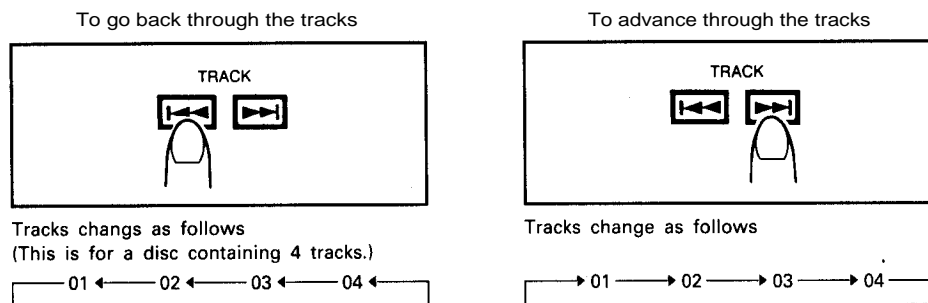

Figure 10

- When a track is selected, the DN-2700F automatically cues to the point at which the sound begins, skipping silent sections at the beginning of tracks. (Cue to Music)

(3) Starting Playback

- Press the PLAY/PAUSE button during pause or cue mode to start playback.
- Playback begins immediately when the PLAY button is pressed. (Instant Play Start)
The PLAY/PAUSE LED lights when playback starts.
- The point at which playback starts is automatically stored in the memory as the cue point. When the CUE button is pressed, the pickup then returns to the cue point (the point at which playback started). (Back Cue)

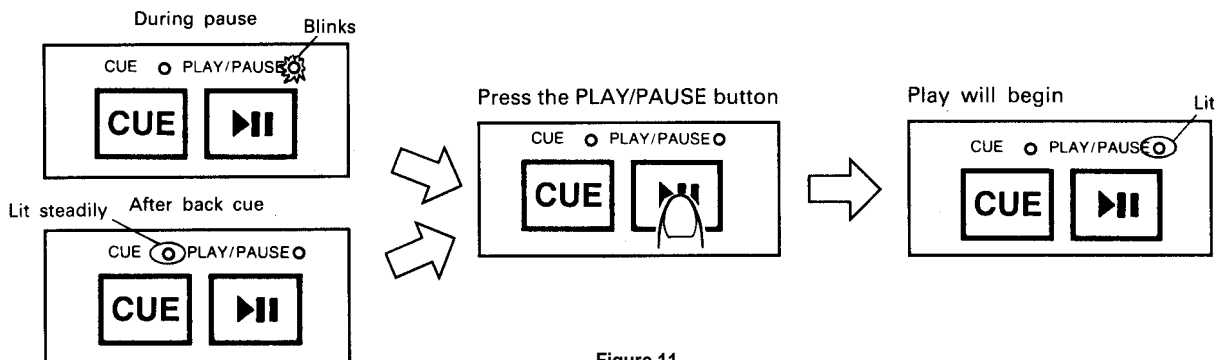

Figure 11

- When the SINGLE indicator is lit, playback stops automatically at the end of that track.
- When the CONTINUE indicator is lit, playback continues until the end of that disc.

(4) Stopping Playback

There are two ways to stop playback.

- 1 Press the PLAY/PAUSE button during playback to pause at that point.
- 2 Press the CUE button during playback to return to cue mode at the position at which playback started. (Back Cue)

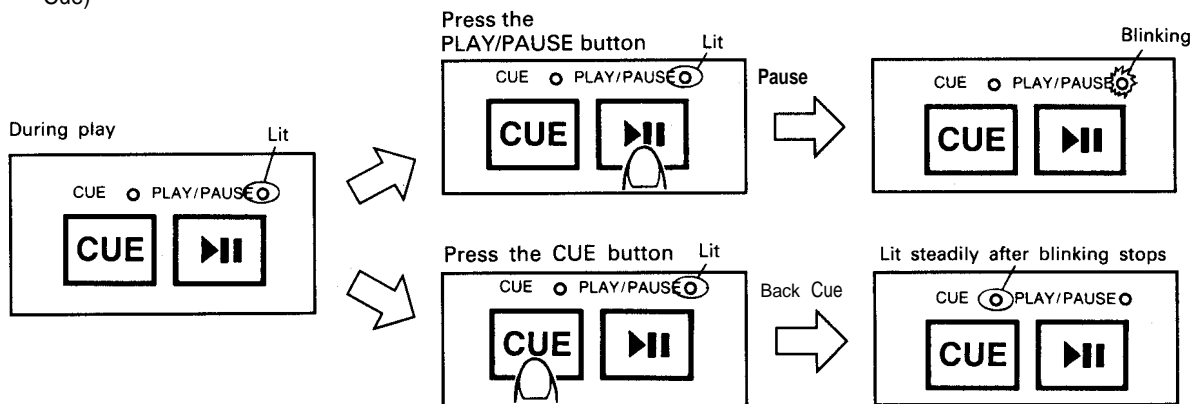
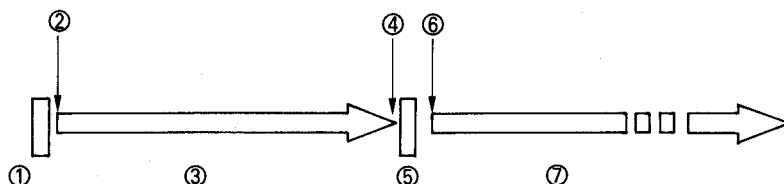

Figure 12

(5) Pausing

Press the PLAY/PAUSE button to switch between play and pause mode. The PLAY/PAUSE LED blinks when the pause mode is set. Figure 13 shows the relationship between the play and pause.



- 1 The player has completed the cue or pause operation and is waiting for the play start command.
- 2 When the PLAY/PAUSE button is pressed, playback starts and the cue point is stored in the memory.
- 3 Playing
- 4 The pause mode is set when the PLAY/PAUSE button is pressed again.
- 5 Pausing
- 6 Playback resumes when the PLAY/PAUSE button is pressed again.
- 7 Playing

Figure 13

(6) Cueing

- "Cueing" is the action of moving to a specified point (the cue point) and waiting for playback to begin (cue mode). When the PLAY/PAUSE button is pressed after cueing, playback starts immediately. (Instant Start)
When the track search operation is completed after pressing the TRACK buttons, the player locates the position at which the sound starts and automatically cues there. (Cue to Music)
- If the CUE button is pressed during the search operation with the jog dial or the scanning operation with the shuttle dial, the point at which the button is pressed is set as the cue point and cueing starts. Figure 14 shows the relationship between the play and back cue operations.

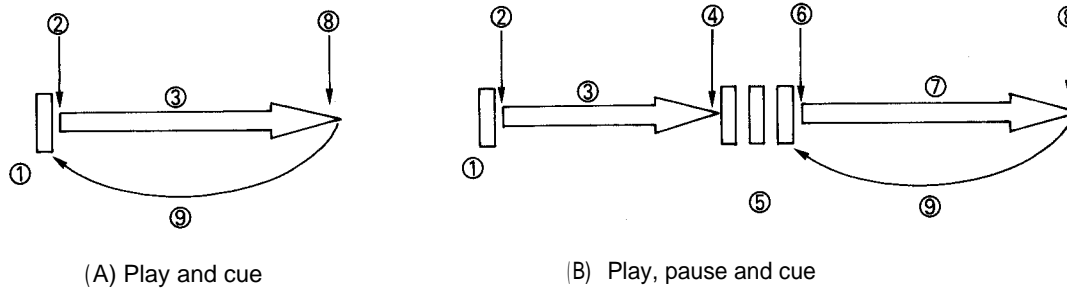

- (A) Play and cue
- (B) Play, pause and cue
- ① The player has completed the cue or pause operation and is waiting for the play start command.
 - ② When the PLAY/PAUSE button is pressed, playback starts and the cue point is stored in the memory.
 - ③ Playing
 - ④ The pause mode is set when the PLAY/PAUSE button is pressed again.
 - ⑤ Pausing
 - ⑥ When the PLAY/PAUSE button is pressed again, playback resumes and the new cue point is stored in the memory.
 - ⑦ Playing
 - ⑧ Press the CUE button.
 - ⑨ The pickup returns to the cue point. (Back Cue)

Figure 14

(7) Searching

Searching is the function which allows you to continuously monitor a certain section of the disc and manually change the playback position in small increments. Searching is used to set playback start points and loop points with precision.

- Turn the jog dial while in the play, pause or cue mode to begin searching. The sound for one revolution of the disc is output repeatedly. The point at which the sound starts (the search point) is indicated on the LCD.
- When the jog dial is turned, the point from which the sound is output moves a number of frames corresponding to the number of clicks, and the time display on the LCD also changes.
- The FINE button selects the resolution of the jog dial. When the FINE indicator is lit, the disc moves 1 frame for each click, and when it is off, the disc moves 10 frames with each click.
- The search point moves in the forward direction when the jog dial is turned clockwise, in the reverse direction when the jog dial is turned counterclockwise.

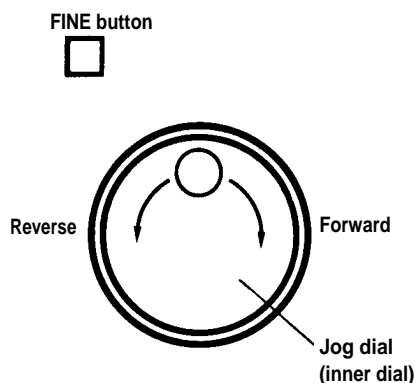

Figure 15

The search point displayed on the LCD during the search operation is automatically stored in the memory as the cue point.

If the jog dial is turned while in play mode, playback resumes automatically once the jog dial is released.

(8) Scanning

- Scanning allows you to move quickly forward or backward through the CD while monitoring the sound, and is used, for example, to locate a specific section in a song.
- Turn the shuttle dial while the player is in the play, pause or cue modes to begin scanning. The disc moves rapidly forward or backward and the sound is output. The current point (scan point) is indicated on the LCD.
- The scanning speed depends on how far from the center point the shuttle dial is turned. The more it is turned, the faster the scanning speed.
- Turn the shuttle dial clockwise to scan in the forward direction, counterclockwise to scan in the reverse direction.

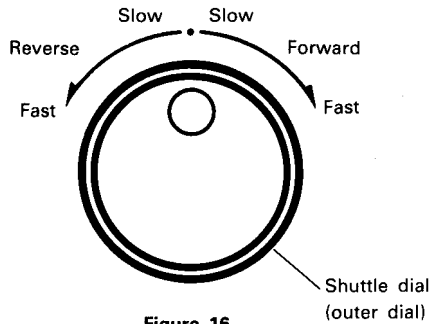

Figure 16

- The scanning point indicated on the LCD is automatically stored in the memory as the cue point.
- When the shuttle dial is released during scanning, it returns to the neutral position, scanning stops and the search mode is set. However, if scanning was started from play mode, playback resumes.

4 MATCHING THE BEATS PER MINUTE (BPM)

- With the DN-2700F, there are two ways to adjust the playing speed and match the BPMs of the two CDs:
 - Use the pitch slider to adjust the BPM statically. One of three adjustment ranges can be selected.
 - Use the PITCH BEND buttons to change the BPM temporarily. Use this after adjusting the BPM with the pitch slider.

(1) Pitch Slider

- To adjust the BPM by sliding the pitch slider up or down, first press the PITCH button to enable the pitch slider. The PITCH LED will turn on.
- With the pitch slider, the pitch can be adjusted within one of three ranges ($\pm 4\%$, $\pm 8\%$ or $\pm 50\%$). The LEDs indicate which range is selected.
- The BPM decreases when the pitch slider is moved upwards, increases when the pitch slider is moved downwards.

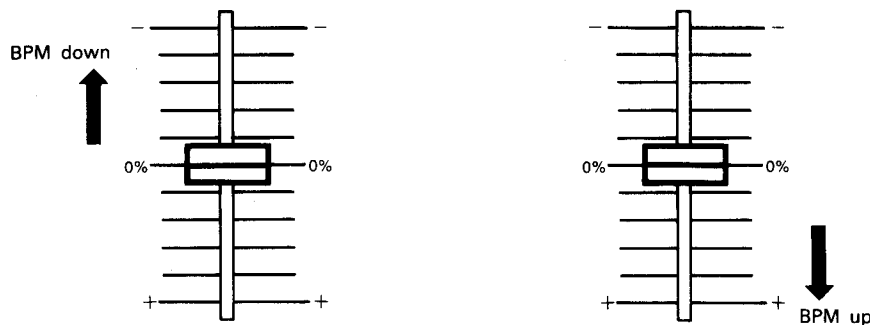

Figure 17

(2) Pitch Bending

- The BPM increases or decreases temporarily while the PITCH BEND+ or PITCH BEND- button is pressed.
- The extent to which the PITCH BEND button changes the BPM is proportionate to the amount of time the button is pressed. The longer the button is held down, the greater the percentage of change.
- The PITCH BEND button changes the BPM within a range of $\pm 10\%$ when the 4% or 8% LED is lit, and within a range of $\pm 50\%$ when the 50% LED is lit.

Figure 18 shows an example of how to use the pitch bend function. In this example, both players are playing and the BPM has already been matched with the pitch sliders.

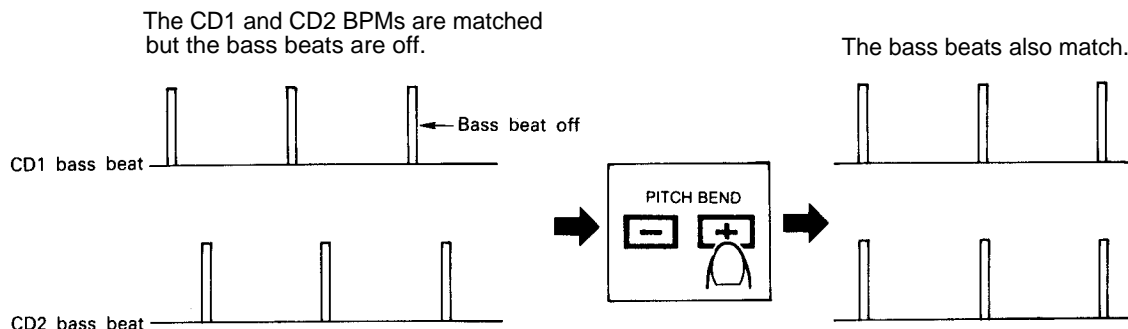

Figure 18

CAUTION: Playability may decrease for some discs when adjusting the BPM in the $\pm 50\%$ range.

5 SAMPLER

The DN-2700F includes a function for recording and playing sections of sound of approximately 6 seconds in length for each of the two players. This sampler function eliminates the need for a separate sampler.

(1) Recording the Sample

- The sample must first be recorded before it can be played. Press the SAMPLER button to start recording. The SAMPLER LED will blink during recording.
- During recording of the sample, the sound being recorded is output for monitoring purposes. When recording is completed, the SAMPLER LED stops blinking, remaining lit, indicating that the sample is ready to be played. Playback also stops.
- The SAMPLER button will function when the player is in the play, cue, pause or search mode.

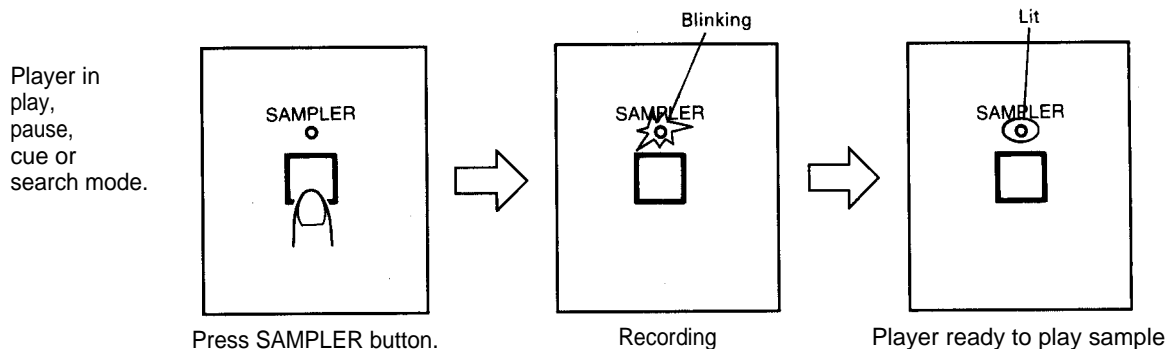

Figure 19

- To record a sample less than 6 seconds long, press the CUE button during recording. Recording stops immediately and the sample is ready to be played.

(2) Playing the Sample

- Sample playback is triggered from the PLAY/PAUSE button. For sample playback, the SAMPLER LED must be lit solid, indicating a sample has been recorded and is ready to be played.
- If the PLAY/PAUSE button is pressed again while the sample is playing, the sample is played over from the beginning. Repeatedly pressing the PLAY/PAUSE button with the proper timing will allow you to achieve "stuttering" effects.
- Playback stops when the end of the recorded sample is reached.
- If the CUE button is pressed while the sample is playing, playback stops immediately.
- For certain effects, you may want normal playback to continue when the end of the sample is reached. To perform this function, press the SAMPLE button (to exit sampler mode) while the sample is playing, then press the PLAY/PAUSE button to begin normal playback operation from the beginning of the sample.

(3) Cancelling the Sampler Mode

- Only sampler functions can be used when in the sampler mode. The sampler mode must be cancelled to use the normal functions.
- Press the SAMPLER button again to cancel the sampler mode and return to normal operation.

6 LOOP

- The DN-2700F's loop function provides A-B seamless looping, eliminating the need for a separate sampler.

(1) Basic Loop Operation

① Setting the loop points during playback - (Normal setting)

- To clear any previous loop settings, press the CLEAR button, and then press the LOOP button.
- Note that all three LEDs (LOOP, A, B) are off.
- Press the LOOP button. The LOOP LED will blink and playback will start.
- Press the A button during playback to set the loop start point. The A LED will light solid.
- Press the B button during playback to set the loop end point. The B LED will light solid.
- Press the EXIT/RELOOP button to start loop playback from point A.
- When the end point is reached playback starts over immediately from the loop start point (seamless loop).
- To modify the A or B points, see ③ "Trimming the loop points" below.
- Press the LOOP button again to cancel loop mode. The LOOP LED will turn off.

② Setting the loop points using the search function - (Fine setting).

- To clear any previous loop settings, press the CLEAR button, and then press the LOOP button.
- Find the loop start point using the shuttle wheel and jog dial.
(See 3-(7) Searching and 3-(8) Scanning for instructions on using the shuttle and jog dial.)
- When you've located the desired point, press the A button to set the loop start point. The A LED will light solid.
- Find the loop end point using the shuttle wheel and jog dial.
- When you've located the desired point, press the B button to set the end point. The B LED will light solid.
- Press the LOOP button to prepare the loop for playback. The LOOP LED will blink.
- When the LOOP LED stops blinking and is lit solid, the loop is ready for playback. Note that all three LEDs (LOOP, A, B) are lit solid.
- Press the PLAY/PAUSE button to start loop playback.
- To modify the A or B points, refer to ③ "Trimming the loop points" below.
- Press the LOOP button again to cancel loop mode. The LOOP LED will turn off.

③ Trimming the loop points

- If you are not satisfied with the current loop point settings, you can trim the start or end points accurately using the jog dial.
- To trim the start point, press the A button. The A LED will turn from solid to blinking to indicate it's ready for trimming. Also, the LOOP LED will turn off.
- Use the jog dial to find the new loop start point.
- When you've found the desired point, press the A button. The new loop start point is set.
- You can trim the loop end point using the same procedure as above, except you have to press the B button instead of the A button.
- After you finished the trimming procedure, press the LOOP button to prepare the loop for playback. The LOOP LED will start blinking.
- When the LOOP LED stops blinking, the loop is ready for playback.

④ Loop playback

- Once the loop is ready for playback (the LOOP LED is lit solid), press the PLAY/PAUSE button. Loop playback begins from the start point (A).
 - When the end point (B) is reached, playback starts over immediately from the loop start point (seamless loop).
- CAUTION: The negative range of the pitch and pitch bend control is limited to -20% during loop playback. However, the full positive 50% range is still available.

⑤ Stopping loop playback

- Loop playback is repeated until loop mode is exited or canceled using one of the following methods:
- Press the LOOP button to cancel loop mode and continue normal playback when the B point is reached.
- Press the CUE button to stop loop playback and cue to the current cue point.
- Press the EXIT/RELOOP button to exit the loop and continue normal playback when the B point is reached (See (3) Exit and Re-loop below)

⑥ Clearing loop points

- Pressing the CLEAR button and then the LOOP button clears all loop information. The LOOP, A, and B LEDs will turn off.
 - Pressing the CLEAR button and then the A button clears the start point "A" only.
 - Pressing the CLEAR button and then the B button clears end point "B" only.
- CAUTION: The player can not clear the loop points during loop playback operation. Also never press the CLEAR button and the LOOP, A, or B buttons at the same time.

(2) Starting Loop Playback From a Cue Point Before The Normal Start Point "A"

- After the loop start and end points have been set, the point at which playback starts can be moved to a point before the loop start point A.
- This function allows you to seamlessly switch from normal playback to loop playback.

CAUTION: To start playback before the loop start point, it is necessary that duration of loop is longer than several frames. If the duration is not longer than this, the LOOP LED will turn off when you press the CUE button, indicating that loop playback is not possible.

① Starting playback from a previously set cue point

- After the preparation for loop playback is completed (LOOP, A, B LEDs lit solid) press the CUE button. The player moves to the pre-set cue point. Note that the three loop LEDs stay lit. (If the loop LED turns off, see CAUTION above)
- Press the PLAY/PAUSE button to start playback. When the loop start point is reached loop playback will start.

② Setting a new cue point after the loop is ready

- Set up a loop and prepare the loop for playback as described above.
- When the loop is ready (LOOP, A, B LEDs will be lit solid), press the LOOP button to temporarily disable the loop (LOOP LED will turn off).
- Turn the shuttle or jog dial counterclockwise to locate the point where playback will start. This point must be before the A point.
- Press the CUE button to set this as the cue point.
- Press the LOOP button again to prepare the unit for loop playback. The LOOP LED will light solid and the unit will cue to the A point.
- Press the CUE button. The player will cue to cue point, and the LOOP LED will remain lit (if the loop LED turns off, see CAUTION above)
- Press the PLAY/PAUSE button to start playback. When the loop start point is reached, loop playback will start.

(3) Exit and Re-loop

- The Exit and Re-loop functions which are unique to the DN-2700F allow you to exit the loop, instantly return to the loop at any time.

① Exit

- Press the EXIT/RELOOP button during loop playback to restore normal playback. When the B point is reached, the LOOP LED will blink and the disc will continue playing beyond the B point.

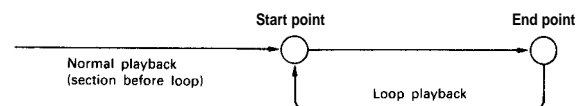

Figure 20

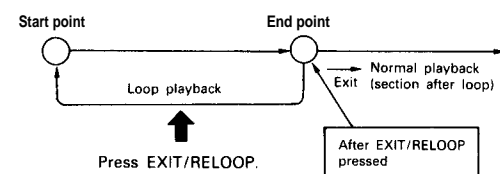

Figure 21

- The operation shown in Figure 20 can be combined with the Re-loop function to play a certain section of a track repeatedly as many times as desired stretching out the song. (Figure 22)

② Re-loop

- The re-loop function is activated by pressing the EXIT/RELOOP button again after exiting loop playback using EXIT/RELOOP button as described above. The Re-loop function resumes loop playback from the A point (the LOOP LED is again lit solid).

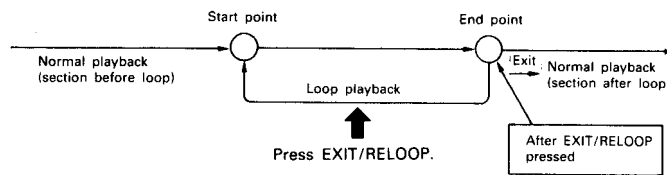

Figure 22

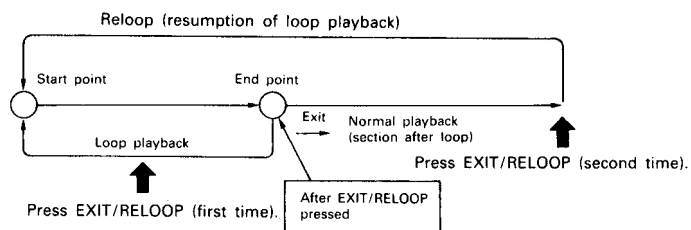

Figure 23

7 MEMORY

- The DN-2700F has the capability to store disc identification information and start/end point playback data in memory.
- The memory function uses the currently loaded discs only. Discs can not be swapped during memory play.

(1) Types of Memory Playback Data

- Memory data must be entered and stored in advance before performing memory playback. There are two types of data:
 - Type 1 - play start data
 - Type 2 - play start and play end data

Each start/end point may consist of one of the following:

- Track number only (i.e. Track 4)
- Track number and time data (i.e. Track 4, 2 min, 5 sec).
- Memory data can be entered using the number keys and the jog/shuttle controls.
- Up to 99 steps of memory data can be stored. Each start or end point occupies one step, so Type 2 data occupies 2 memory steps.

① Type 1 - Play Start Data only

- Play Start data specifies a location on the disc at which playback will begin in memory play mode.
- When memory playback is started using Play Start data only, playback stops at the end of the track.
- The Play Start point can be a track number only or a track number and specific time.

② Type 2 - Play Start and End Data

- Play End data may be combined with Play Start data to specify both starting and ending playback points for a disc in memory play mode.
- When memory playback is started using Play Start and End data, playback stops at the position specified by the end data.
- The Play Start and End points can be track numbers only or track numbers and specific time.

(2) Disc Identification

- Disc identification information is automatically stored in each memory step along with the start/end point data. Therefore, each memory step may be applied only to the disc for which it is programmed.
- When a disc which has memory data is loaded into the unit, it is automatically identified and the MEMORY indicator in the LCD display will blink.
- A maximum of 16 discs can be identified. Each disc may be referenced in an number of memory steps, with an overall limit of 99 memory steps.

(3) Inputting the Memory Data

The following examples demonstrate how memory data is input. These examples assume both discs are loaded.

① Storing start track data only (track 12 in this example)

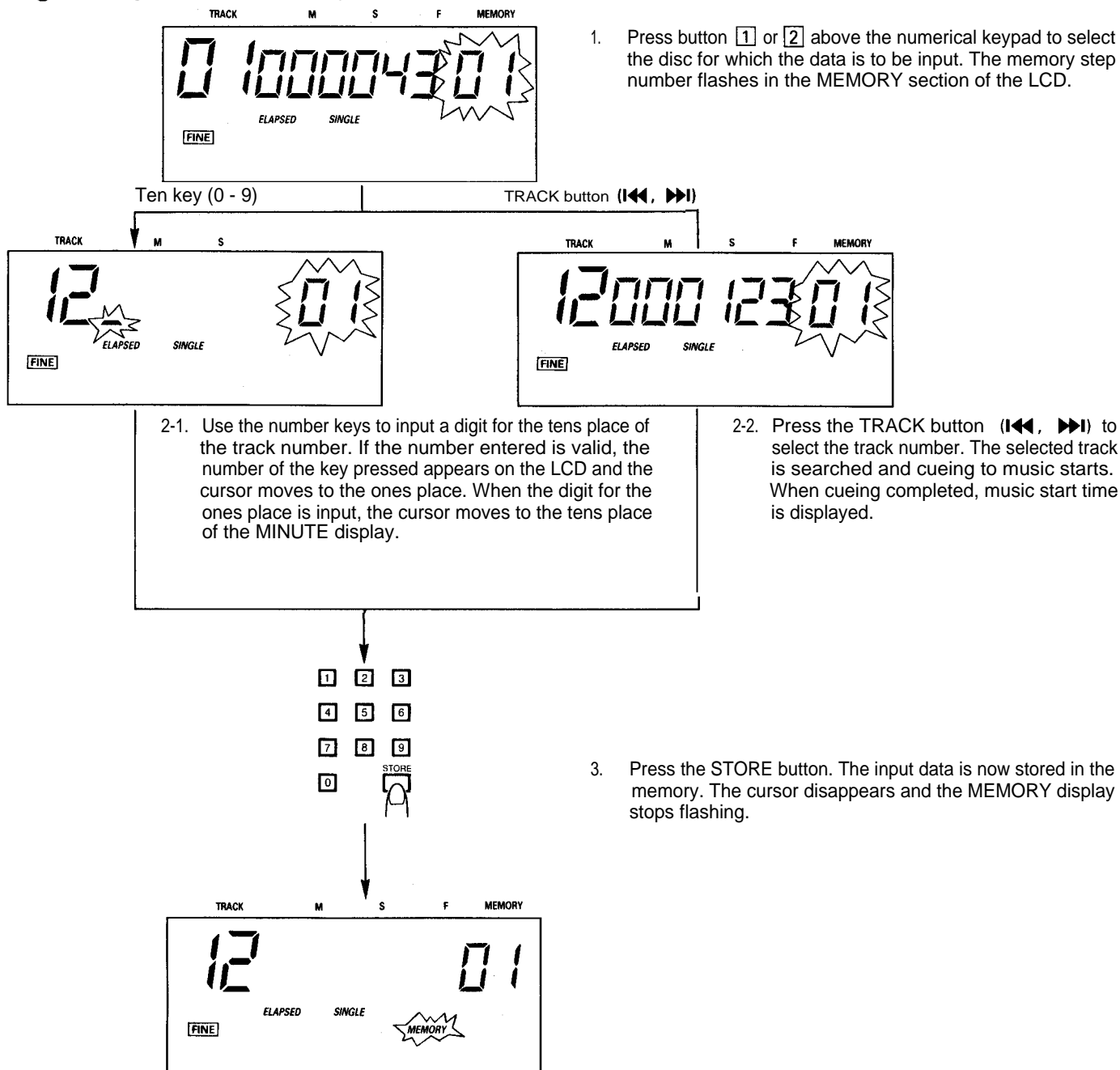

Figure 24

Repeat steps 1 to 3 above to store more start track data. The blinking MEMORY location increases by one each time a new set of data is stored. Remember that these start tracks apply to the currently loaded disc only.

CAUTION: The current digit in the TRACK display flashes if an invalid number is entered.

② Storing start and end track data

1. Press button **1** or **2** above the numerical key pad to select the disc for which the data is to be input. The memory step number flashes in the MEMORY section of the LCD.

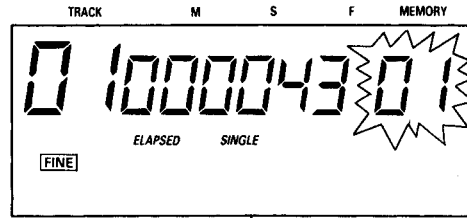

Ten key (0 ~ 9)

TRACK button (⏮, ⏭)

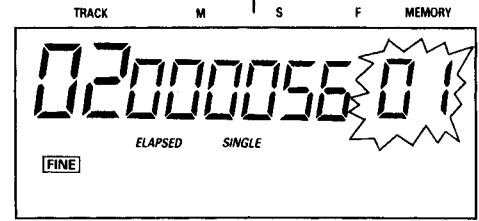
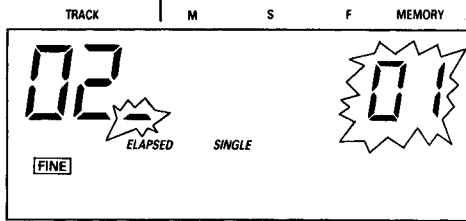

2-1. Use the number keys to input a digit for the tens place of the track number. If the number entered is valid, the cursor will move to the ones place. When the digit for the ones place is input, the cursor moves to the tens place of the MINUTE display.

2-2. Press the TRACK button (⏮, ⏭) to select the start track number. The selected track is searched and cueing to music starts. When cueing completed, music start time is displayed.

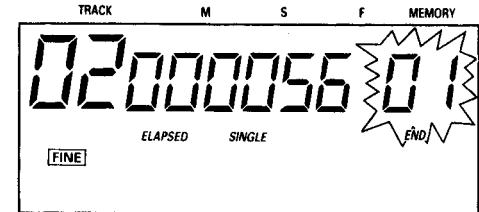
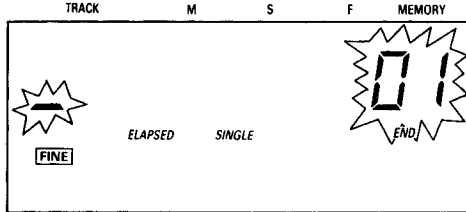
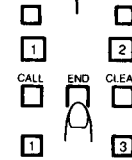
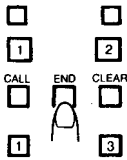

3. Press the END button. The start track number is stored in the memory, and the end track number can now be set. The "END" indicator on the LCD lights.

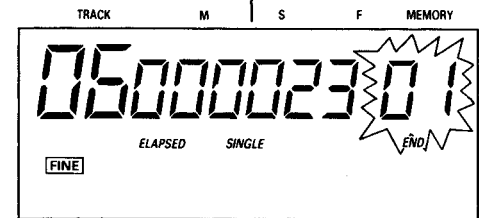
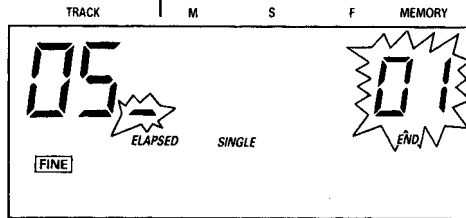

4-1. Input a two digit number for the end track number using the same procedure as above. Memory playback will stop at the end of selected track.

4-2. Press the TRACK button (⏮, ⏭) to select the end track number. The selected track is searched and cueing to music starts. When cueing completed, music start time is displayed. Memory playback will stop at this time.



5. The press the STORE button to store the start and end track data in memory. The cursor disappears and the MEMORY display stops flashing.

Figure 25

Repeat steps 1 to 5 above to store multiple sets of data. The blinking MEMORY location increases by one each time a new set of data is stored.

CAUTION: The current digit in the TRACK display flashes if an invalid number is entered.

③ Storing track and time data

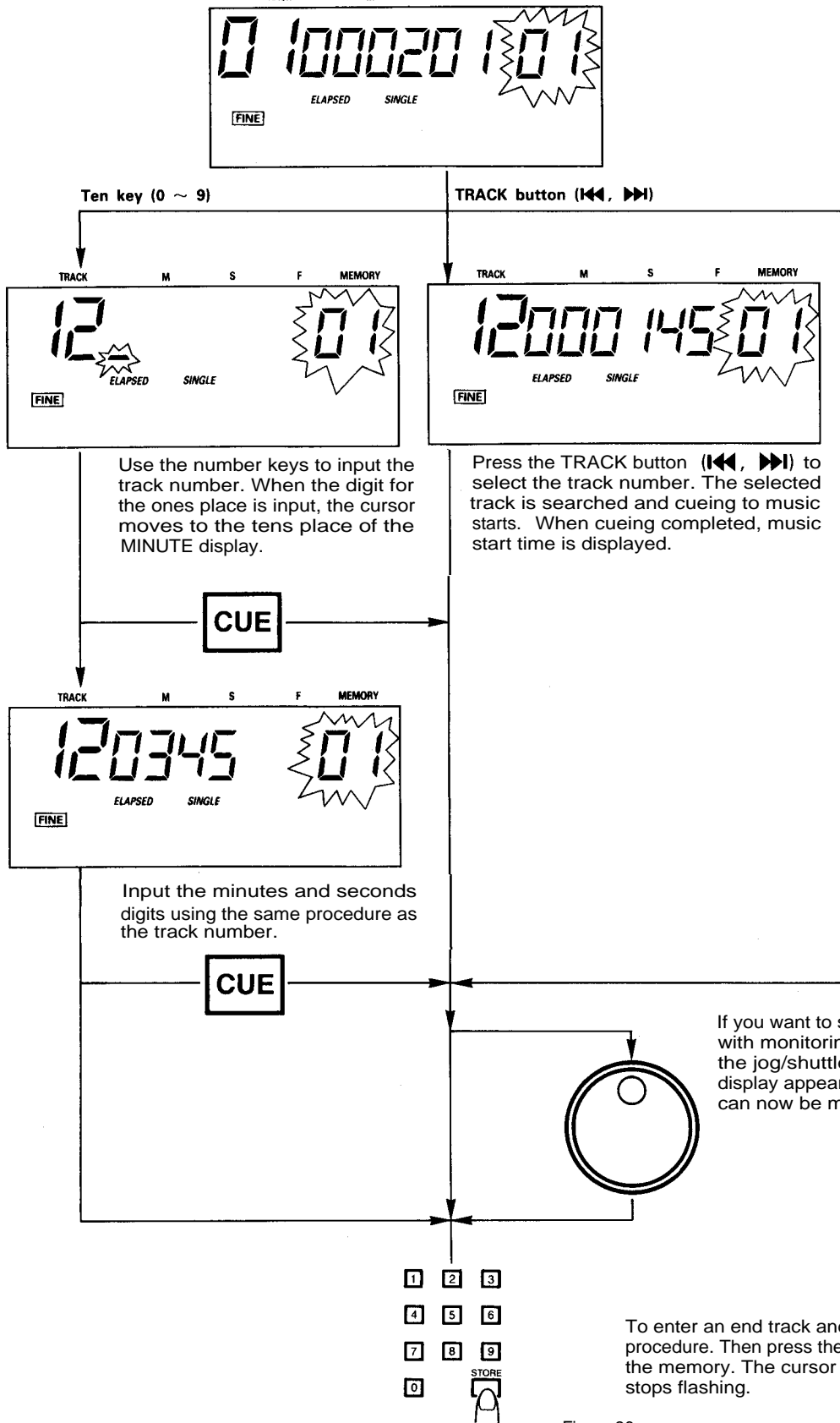

Pressing the **1** or **2** button in cue, pause, search mode, you can input the current track and time for memory data.

Figure 26

Repeat above steps to store multiple sets of data. The blinking MEMORY location increases by one each time a new set of data is stored.

CAUTION: The current digit in the TRACK display flashes if an invalid number is entered.

(4) Executing Memory Playback

- ① Load a disc or discs for which memory data has been previously stored. If a disc has memory data, it is identified and the MEMORY indicator on the LCD lights until press any button.
- ② Press the MEM CUE button to prepare for memory playback. The MEM CUE LED flashes and preparations begin. The MEMORY indicator lights.

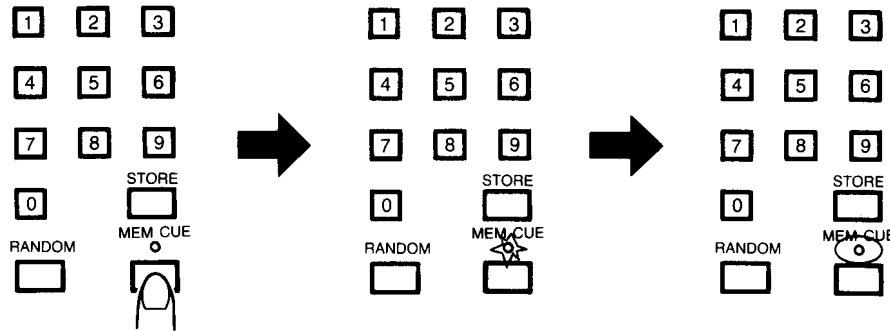

Figure 27

- ③ When memory playback is ready, the MEM CUE LED stops flashing and remains lit. Loaded discs which have memory data are cued to the start point from the first memory step for that disc. The playback order is indicated in the memory section of the LCD.
- ④ Press the PLAY/PAUSE button for the side on which the PLAY indicator on the LCD is flashing to start memory playback. The "MEMORY PLAY" indicator appears on the LCD. All memory steps for the currently loaded discs will be played in order.

Press the PLAY/PAUSE button for the side on which the PLAY indicator is flashing.

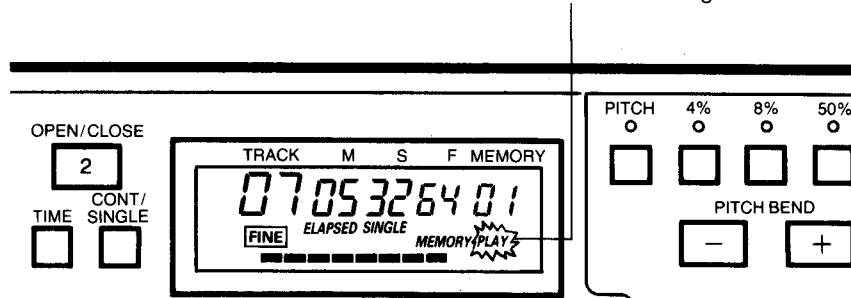

Figure 28

- In order to eliminate silence between tracks, Cue to Music and End Detect are implemented in memory play mode. The point at which the sound starts on the track is found during preparations for memory playback (Cue to Music). In addition, the point at which the sound ends on the track is also found (End Detect).
- ⑤ If the SINGLE indicator is lit during memory play mode, all memory steps for the currently loaded discs will be played only once. If the CONTINUE indicator is lit, playback resumes from the beginning of the first track in the memory, and repeats until memory playback is interrupted. Continuous/Single mode selection must be performed after memory play mode is ready (the MEMORY LCD indicators and MEM CUE LED are lit solid).
- ⑥ Press the MEM CUE, PLAY/PAUSE or CUE buttons to interrupt memory playback. The operation differs as follows depending on which button is pressed:

MEM CUE button	Exit memory play mode, continue normal play.
PLAY/PAUSE button	Pause, continue memory play mode.
CUE button	Back cue to the point at which it started for that track, continue memory play mode
- ⑦ To cancel the memory play mode, open the disc holder.

CAUTION: If pressing the following buttons, memory playback will be cancelled, although memory playback reach the end of current memory step, next memory playback can not start.

TRACK (I◀◀, ▶▶I)	SAMPLER	LOOP
A	B	JOG/SHUTTLE
Ten key (0 -r 9)		
PLAY/PAUSE	CUE	

Memory playback will not be cancelled if press PLAY/PAUSE and CUE button of memory playing side.

(5) Cue to Memory

It is also possible to cue to the point which is read from memory data. After cueing, you can use DN-2700F same as normal mode.

- ① Load a disc or discs for which memory data has been previously stored. If a disc has memory data, it is identified and the MEMORY indicator on the LCD lights.
- ② Press the MEM CUE button to prepare for memory playback. The MEM CUE LED flashes and preparations begin. The MEMORY indicator on LCD lights.
- ③ When memory playback is ready, the MEM CUE LED stops flashing and remains lit.
- ④ Select a memory number which you want using numerical key. After 2 digit data was input, pickup moves to the point which specified with memory data. Memory playback is cancelled and the PLAY indicator on the LCD will not light even if playback starts.
- ⑤ After cue to memorized point, normal function will be available.
- ⑥ To exit memory play mode, press MEM CUE button.

(6) Memory Call

Pressing the CALL allows each memory step to be displayed on the LCD display in consecutive order. Memory steps may also be inserted or deleted in memory call mode.

- ① Displaying the memory data
Press the CALL button to set the memory call mode. The data for memory step 01 appears on the display. Press the CALL button again to display the next step.
- ② Clearing a memory step
Use the CALL button to display the step you want to clear.
Press the CLEAR button, then press the STORE button to clear that step.
- ③ Inserting a memory step
Use the CALL button to display the memory step which you want to follow the new memory step.
Insert the new memory data using the normal data entry procedure.
- ④ Changing a memory step
Once delete a MEMORY that you want to change, and input correct MEMORY again as the regular procedure.

(7) Clearing all Memory Data

To clear all memory data, press the CLEAR button twice, then press the STORE button.

(8) Advanced Memory Functions

The jog/shuttle dials may be used to insert memory data, including frame information, using the search and scan functions.

- ① First, input the track, minutes and seconds using the regular data enter procedure. (Refer to Figure 26)
For example; if track 12, 03:45 is input, the display reads as shown in Figure 29.

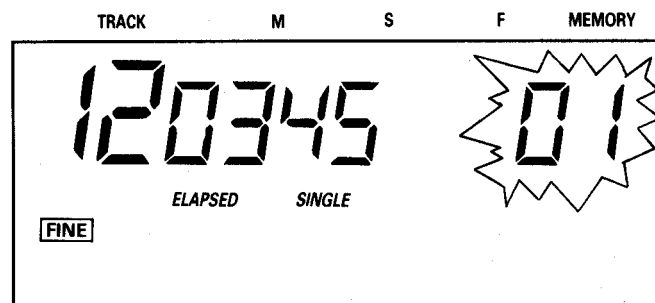

Figure 29

- ② Now press the CUE button to move to the displayed position and enable the jog/shuttle dials.
- ③ Once the CUE LED lights, turn the jog dial to begin searching. The frame display appears on the LCD, and the current position can now be monitored.

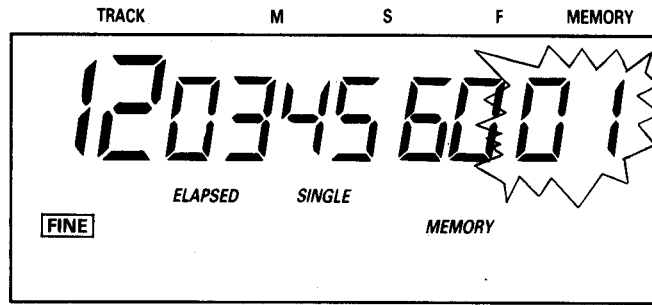

Figure 30

- ④ When the desired position is reached, continue with the normal data entry procedure. For example, press STORE to store this point, or END to enter and end point.

8 RANDOM PLAYBACK

- Random playback will play the tracks from both discs alternately and in random order.

(1) Preparing for Random Playback

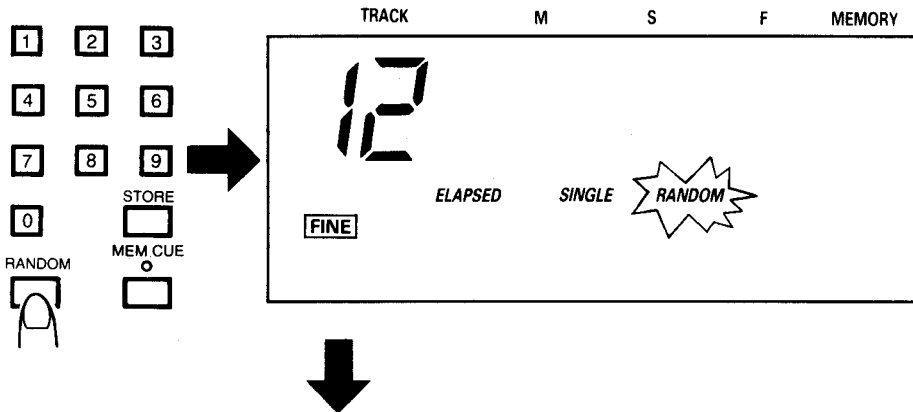

With discs loaded in each of the disc holders, press the RANDOM button. The RANDOM indicator flashes on the display, and a random track is cued on each disc.

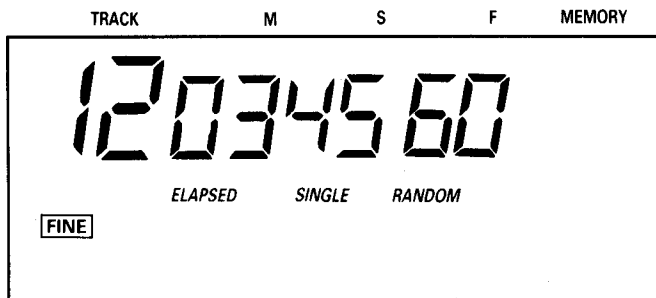

When random playback mode is ready, the RANDOM indicator and track number stop flashing, remain lit, and the CUE LED for the side to be played first lights.

Figure 31

(2) Executing Random Playback

- Press the PLAY/PAUSE button for the side whose CUE LED is lit to begin random playback. Once that track is played, playback begins immediately on the other disc. A new randomly selected track is cued on the disc which has finished playing.

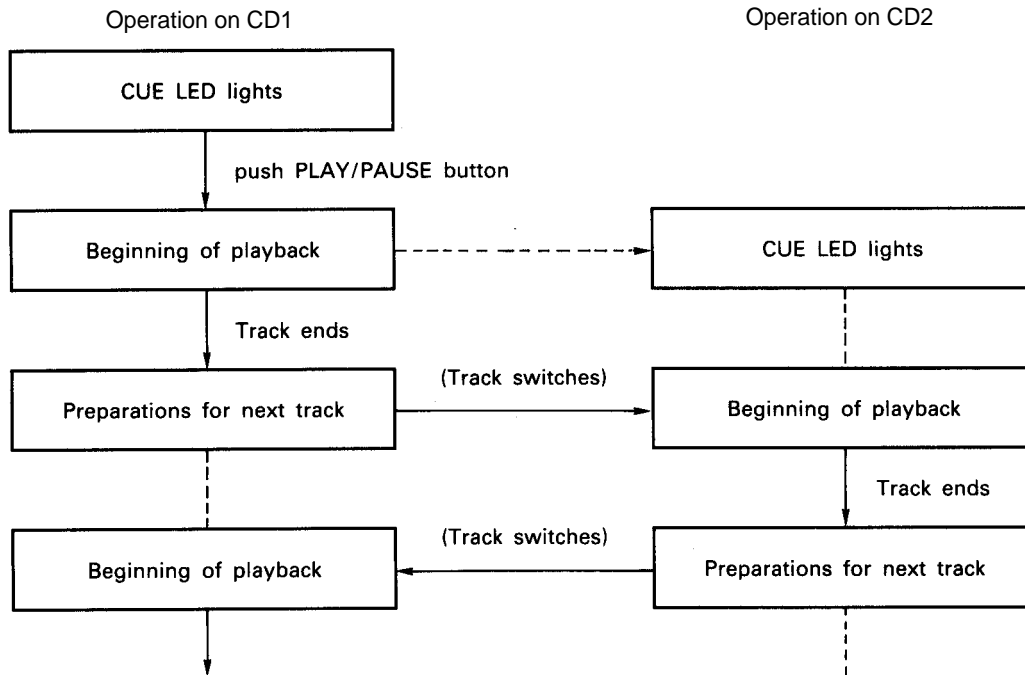

Figure 32

- In order to eliminate silence between tracks, Cue to Music and End Detect are implemented in random play mode. The point at which the sound starts on the track is found during preparations for random playback (Cue to Music). In addition, the point at which the sound ends on the track is also found (End Detect).

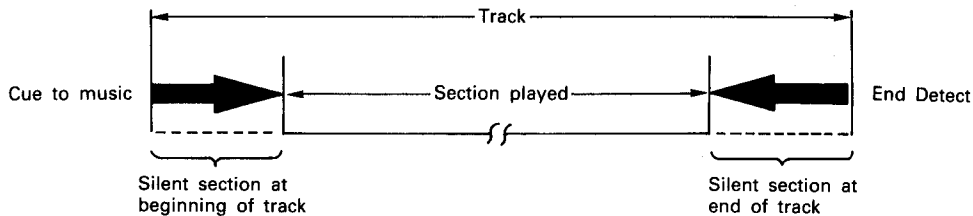

Figure 33

- This is the same as the operation performed during memory playback.
- If the SINGLE indicator is lit, random playback stops when all tracks on both discs are played once (no tracks are repeated). If the CONTINUE indicator is lit, the random playback function starts over after all tracks are played once. Continuous Single mode selection must be performed when random play mode is ready (the RANDOM LCD indicators are lit solid and the CUE LED for the side to be played first is lit).
- Press the PLAY/PAUSE or CUE button to interrupt random playback.
- To cancel the random play mode, press the RANDOM button again.

9 DIRECT ACCESS

- Specific positions on the disc can be accessed directly by using the number keys and the CUE and PLAY/PAUSE buttons.
- Select the disc and input the track number and time (minutes and seconds) using the same procedure as inputting memory data.
- Press the CUE or PLAY/PAUSE button once the point to be accessed directly appears on the LCD.
- If the CUE button is pressed, the pickup moves to the displayed position and cues there.
- If the PLAY/PAUSE button is pressed, playback begins from the displayed position.

10 BEFORE SWITCHING OFF THE POWER

When you have finished using the CD player, before switching off the power, be sure that the disc holder has been closed with the OPEN/CLOSE button.

CAUTION:

Do not forcibly close the disc holder when the power is off.
It may damage the unit when it is transported.

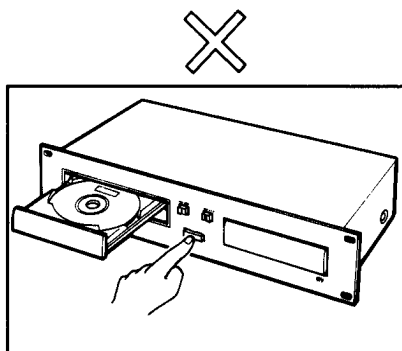

Do not switch off the power when the disc holder is open.

POWER OFF

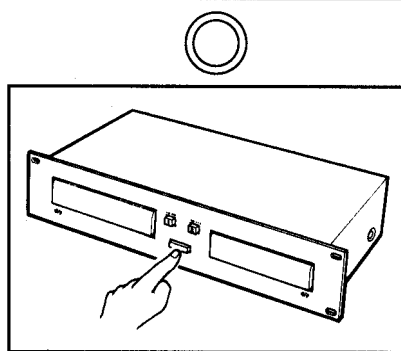

Switch off the power after the disc holder has been closed with the OPEN/CLOSE button.

POWER OFF

Figure 34

11 COMPACT DISCS

1. Precautions on handling compact discs
 - Do not allow fingerprints, oil or dust to get on the surface of the disc.
If the disc is dirty, wipe it off with a soft dry cloth. We recommend using DENON's AMC-20/21 CD CLEANER.
 - Do not use benzene, thinner, water, record spray, electrostatic-proof chemicals, or silicone-treated cloths to clean discs.
 - Always handle discs carefully to prevent damaging the surface; in particular when removing a disc from its case or returning it.
 - Do not bend the disc.
 - Do not apply heat.
 - Do not enlarge the hole in the center of the disc.
 - Do not write on the label (printed side) with a hard-tipped implement such as a pencil or ball point pen.
 - Condensation will form if a disc is brought into a warm area from a colder one, such as outdoors in winter. Do not attempt to dry the disc with a hair dryer, etc.
2. Precaution on storage
 - After playing a disc, always unload it from the player.
 - Always store the disc in the jewel case to protect from dirt or damage.
 - Do not place discs in the following areas:
 - 1) Areas exposed to direct sunlight for a considerable time.
 - 2) Areas subject to accumulation of dust or high humidity.
 - 3) Areas affected by heat from indoor heaters, etc.

12 SPECIFICATIONS

GENERAL

Type:	Twin mechanism compact disc player with wired controller		
Disc type:	Standard compact discs (12 cm and 8 cm discs)		
Dimensions:	Player unit:	482 (W) x 88 (H) x 252 (D) mm (without feet)	
		19" (W) x 3-15/32 (H) x 9-55/64 (D)	
	Control unit:	482 (W) x 132 (H) x 40 (D) mm (without feet)	
		19" (W) x 5-13/64 (H) x 1-37/64 (D)	
Installation:	19-inch rack mountable		
	Player unit:	2U	
	Control unit:	3U	
Weight:	Player unit:	6 kg (13.23 lbs.)	
	Control unit:	3 kg (6.614 lbs.)	
Power supply:	U.S. and Canadian models:	120 V AC	±10%, 60 Hz
	European models:	230 V AC	±10%, 50 Hz
	Multi-voltage models:	120/220/240 V AC	±10%, 50/60 Hz
Power consumption:	26W		
Environmental conditions:	Operational temperature:	5 to 35 °C	(41 to 95°F)
	Operational humidity:	25 to 85%	(no condensation)
	Storage temperature:	-20 to 60 °C	(4 to 140°F)
Accessories:	Connecting cord (2 pairs for left and right channels)		
	Control cord (5m, 15 feet)		

AUDIO SECTION

Quantization:	18-bit linear per channel
Sampling frequency:	44.1 kHz at normal pitch
Oversampling rate:	8 times
Frequency response:	10 to 20,000 Hz
Total harmonic distortion:	0.003%
Signal to noise ratio:	103 dB
Dynamic range:	98 dB
Channel separation:	100 dB
Output level:	2.0 V
Load impedance:	10 kohm or more

FUNCTIONS

Instant start:	Within 10 msec.	
Variable pitch:	4% range:	±4% or more
	8% range:	±8% or more
	50% range:	±50% or more
Pitch bend:	4% and 8% ranges:	±10% or more
	50% range:	±50% or more
Sampling length:	5.94 sec. at normal pitch	
Search accuracy:	Fine mode;	1/75 sec. (1 subcode frame)
	Coarse mode;	10/75 sec. (10 subcode frames)
Max. scan speed:	Over 20 times normal speed	
Max. memory steps:	99 steps	

* Specifications and design are subject to change without notice for purpose of improvement.